

PMD MINIATURE AIR DRYERS

PMD MINIATURE AIR DRYERS

For Ultra-Dry Air to 2 SCFM

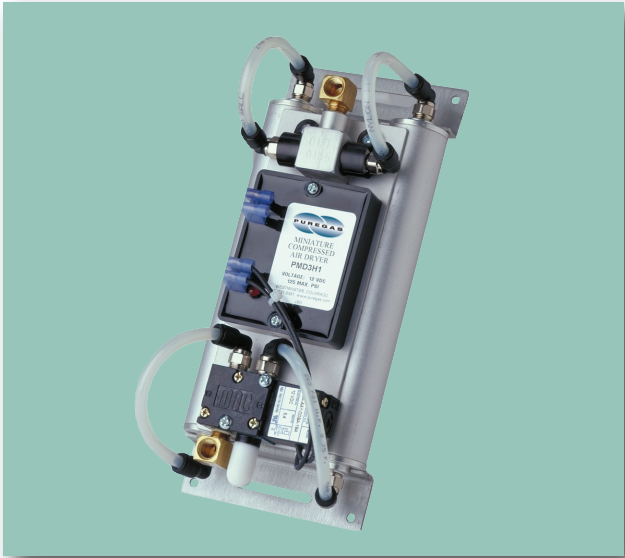

Miniature, regenerative compressed air dryers capable of achieving dewpoints of better than -100°F (-73°C) for flows to 2 SCFM (60 lpm).

Ideal for OEM and point-of-use applications requiring ultra-dry air, small size and economical pricing. Fits easily into a shoe box.

Accessories include inlet and outlet filtration, flow and pressure regulation and a NEMA-4 enclosure.

PRODUCT FEATURES

- Ultra-dry air to -100°F (-73°C) dewpoint (-40°F standard)
- Flow capacities to 2 SCFM (60 lpm) at operating pressures of 50-125 PSIG
- Extremely compact, lightweight anodized aluminum construction
- Easy to install and no regular maintenance required
- Regenerative operation eliminates ongoing expense of desiccant replacement
- Non-corroding purge muffler comes standard for quiet operation
- Governed by solid-state timer for precise control and lower power consumption
- Sizes to match the output air flow of fractional horsepower compressors
- Manufactured in a Lean Manufacturing environment for world-class quality and on-time delivery

TYPICAL APPLICATIONS

- Ozone generation feed gas
- Dilution air for emissions monitoring systems (CEMS)
- Antenna waveguide and microwave tower pressurization
- Analytical instruments and optical purging
- Air bearings, pneumatic motors and actuators
- Low temperature compressed air applications
- Spectrometer and optical purging
- Environmental chambers and glove boxes
- Micro-abrasion and air brushing
- Automotive pneumatic systems



PMD MINIATURE AIR DRYERS - DESCRIPTION OF OPERATION

The dryer employs Pressure Swing Adsorption (PSA) technology to remove water vapor from ordinary compressed air. The 4-way valve directs the wet air into one of the two desiccant chambers, where nearly all of the water vapor is removed. The ultra-dry air leaving the desiccant chamber passes through the outlet shuttle valve to the application. A precision orifice in the outlet shuttle valve disk allows a portion of the dry air to be redirected back through the off-line desiccant chamber, purging it of the accumulated moisture. The purge air then exits the unit through the 4-way valve and muffler. A solid-state timer governs the process by controlling the 4-way valve.

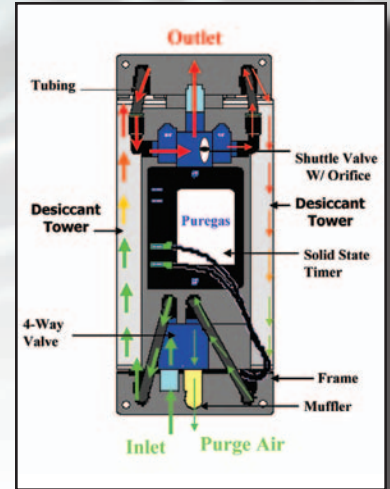

SPECIFICATIONS

| | PMD-S | PMD-M |
|---|-------|-------|
| Inlet Flow in SCFM at 100 PSIG ¹ | 1.2 | 3.2 |
| Outlet Flow in SCFM for -40° F dewpoint ² | 0.9 | 2.4 |
| Outlet Flow in SCFM for -100° F dewpoint ² | 0.7 | 1.9 |
| Reference compressor size (hp) | 1/3 | 1 |
| Dimension A (inches) | 9.3 | 11.4 |
| Dimension B (inches) | 4.0 | 4.5 |
| Dimension C (inches) | 4.0 | 5.0 |
| Weight (lbs) | 2 | 3.6 |

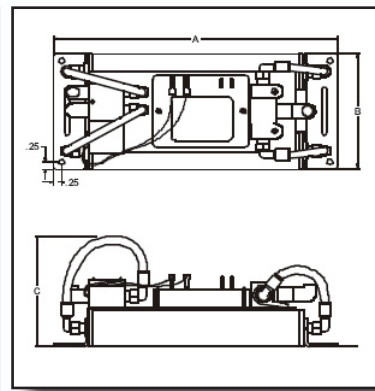

Operating Pressure: 50 to 125 PSIG (maximum)
 Max. Temperature: 120°F Ambient
 Connections: 1/8" NPT
 Power Options: 115 VAC, 230 VAC, 24 VDC & 12 VDC

ORDERING INFORMATION

Bold Options are Standard

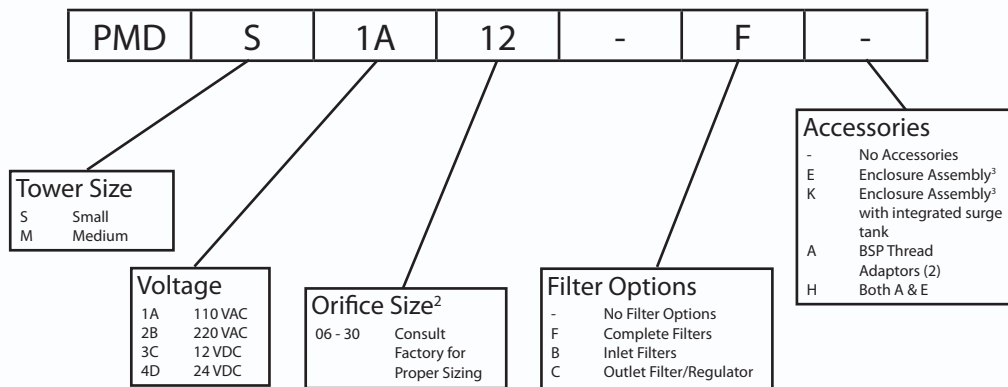

NOTES:

- For flow rates in liters per minute (lpm), multiply flows in SCFM by 28.3.
- Contact factory for outlet flow rates and orifice sizing for inlet pressures less than 100 PSIG. For 100 PSIG operating pressure, a #12 orifice is standard for the PMD-S and a #22 orifice is standard for the PMD-M.
- When selecting enclosure options, the 24 VDC (4D) voltage option must be selected, while the inlet voltage to the unit can be either 110 VAC or 220 VAC. Enclosure assembly includes adjustable flow restrictor, check valve, on/off switch and NEMA4 enclosure.

P011048F14 - 2-yr Warranty Kit, PMD

P011048F22 - Annual Maintenance Kit, PMD