

OPERATING MANUAL

GFC MASS FLOW CONTROLLER



TABLE OF CONTENTS

1. UNPACKING THE GFC MASS FLOW CONTROLLER	1
1.1 Inspect Package for External Damage.....	1
1.2 Unpack the Mass Flow Controller.....	1
1.3 Returning Merchandise for Repair.....	1
2. INSTALLATION	2
2.1 Primary Gas Connections.....	2
2.2 Electrical Connections.....	2
2.2.1 Valve Control Configuration.....	4
2.2.2 Remote LCD Readouts.....	4
2.2.3 Panel Mounting Readouts.....	5
3. PRINCIPLE OF OPERATION	5
4. SPECIFICATIONS	6
4.1 CE Compliance.....	8
4.2 Flow Capacities.....	8
5. OPERATING INSTRUCTIONS	9
5.1 Preparation and Warm Up.....	9
5.2 Flow Signal Output Readings.....	10
5.3 Swamping Condition.....	10
5.4 Setpoint Reference Signal.....	10
5.5 Valve OFF Control (Open Collector NPN Compatible).....	11
5.6 Valve Test/Purge.....	12
6. MAINTENANCE	12
6.1 Introduction.....	12
6.2 Flow Path Cleaning.....	13
6.2.1 Cleaning the Inlet Filter Screen in GFC Models.....	13
6.2.2 Valve Maintenance for GFC17/37/47 Models.....	13
7. CALIBRATION PROCEDURES	15
7.1 Flow Calibration.....	15
7.2 Calibration of GFC Mass Flow Controllers.....	16
7.2.1 Connections and Initial Warm Up.....	16
7.2.2 Zero Adjustment.....	17
7.2.3 SPAN Adjustment.....	17
7.2.4 Linearity Adjustment.....	17
7.2.4.1 Disable Solenoid Valve in GFC17/37/47 Models.....	17
7.2.4.2 Open Motorized Valve in GFC57/67/77 Models.....	17

7.2.5	Connections and Initial Warm Up.....	18
7.2.6	ZERO Adjustment.....	18
7.2.7	25% Flow Adjustment.....	18
7.2.8	50% Flow Adjustment.....	18
7.2.9	75% Flow Adjustment.....	19
7.2.10	100% Flow Adjustment.....	19
7.2.11	Valve Adjustment.....	19
7.2.11.1	Valve Adjustment for GFC17/37/47.....	19
7.2.11.2	Valve Adjustment for GFC57/67/77.....	19
7.2.12	Full Scale Flow Adjustment.....	19
7.2.13	25% Flow Adjustment.....	19
7.2.14	50% Flow Adjustment.....	20
7.2.15	75% Flow Adjustment.....	20
7.2.16	100% Flow Adjustment.....	20
7.2.17	LCD Display Scaling.....	20
7.2.17.1	Access LCD Display Circuit.....	20
7.2.17.2	Adjust Scaling.....	21
7.2.17.3	Change Decimal Point.....	21
8.	TROUBLESHOOTING.....	21
8.1	Common Conditions.....	21
8.2	Troubleshooting Guide.....	21
8.3	Technical Assistance.....	24
9.	CALIBRATION CONVERSIONS FROM REFERENCE GASES.....	24
APPENDIX 1	COMPONENT DIAGRAM.....	25
APPENDIX 2	GAS FACTOR TABLE (“K” FACTORS).....	27
APPENDIX 3	DIMENSIONAL DRAWINGS.....	31
APPENDIX 4	WARRANTY.....	35

1. UNPACKING THE GFC MASS FLOW CONTROLLER

1.1 Inspect Package for External Damage

Your GFC Mass Flow Controller was carefully packed in a sturdy cardboard carton, with anti-static cushioning materials to withstand shipping shock. Upon receipt, inspect the package for possible external damage. In case of external damage to the package contact the shipping company immediately.

1.2 Unpack the Mass Flow Controller

Open the carton carefully from the top and inspect for any sign of concealed shipping damage. In addition to contacting the shipping carrier please forward a copy of any damage report to your distributor or Aalborg® directly.

When unpacking the instrument please make sure that you have all the items indicated on the Packing List. Please report any shortages promptly.

1.3 Returning Merchandise for Repair

Please contact the customer service representative of your distributor or Aalborg® if you purchased your Mass Flow Controller directly, and request a **Return Authorization Number (RAN)**. **Equipment returned without an RAN will not be accepted.** Aalborg® reserves the right to charge an evaluation fee for equipment returned under warranty claims if the instruments are tested to be free from warrantied defects.

Shipping charges are borne by the customer. Items returned “collect” will not be accepted!

It is mandatory that any equipment returned for servicing be purged and neutralized of any dangerous contents including but not limited to toxic, bacterially infectious, corrosive or radioactive substances. No work shall be performed on a returned product unless the customer submits a fully executed, signed SAFETY CERTIFICATE. Please request form from the Service Manager.

2. INSTALLATION

2.1 Primary Gas Connections

Please note that the GFC Mass Flow Controller will not operate with liquids. Only clean gases are allowed to be introduced into the instrument. Contaminated gases must be filtered to prevent the introduction of impediments into the sensor.



Caution: GFC transducers should not be used for monitoring OXYGEN gas unless specifically cleaned and prepared for such application. For more information, contact your distributor or Aalborg®.

Attitude sensitivity of the Mass Flow Controller is $\pm 15^\circ$. This means that the gas flow path of the flow meter must be horizontal within those stated limits. Should there be need for a different orientation of the meter, re-calibration may be necessary. It is also preferable to install the GFC transducer in a stable environment, free of frequent and sudden temperature changes, high moisture, and drafts.

Prior to connecting gas lines inspect all parts of the piping system including ferules and fittings for dust or other contaminants. Be sure to observe the direction of gas flow as indicated by the arrow on the front of the meter when connecting the gas system to be monitored.

Insert tubing into the compression fittings until the ends of the properly sized tubings home flush against the shoulders of the fittings. Compression fittings are to be tightened according to the manufacturer's instructions to one and one quarter turns. Avoid over tightening which will seriously damage the Restrictor Flow Elements (RFE's)!

Compression fittings should not be removed unless the meter is being cleaned or calibrated for a new flow range.

Using a Helium Leak Detector or other equivalent method perform a thorough leak test of the entire system. (All GFC's are checked prior to shipment for leakage within stated limits. See specifications in this manual.)

2.2 Electrical Connection

GFC transducers require a +12VDC (+24VDC optional) power supply with a minimum current rating of 800 mA to operate. The operating power input is supplied via the 15-pin "D" connector located at the side of the flow transducer enclosure. On GFC's purchased without an LCD readout, a readout panel meter, digital multimeter, or other equivalent device is required to facilitate visual flow readings.

A built in SETPOINT potentiometer is used for local control of the flow. Variable analog 0 to 5 VDC (or 4 to 20 mA) reference input is required for remote control.

PIN FUNCTION

- 1 0 to 5 VDC Flow Signal Common
- 2 0 to 5 VDC Flow Signal Output
- 3 Common
- 4 Open (Purge)
- 5 Common, Power Supply
- 6 (unassigned)
- 7 +12 VDC (+24 VDC*) Power Supply
- 8 Remote Setpoint Input
- 9 4 to 20 mA (-) Flow Signal Return (use with 14)
- 10 Remote Setpoint Common (use with 8)
- 11 +5VDC Reference Output for Remote Setpoint
- 12 Valve Off Control
- 13 Auxiliary +12 VDC (+24 VDC*) Power Output (For Loads <100 mA)
- 14 4 to 20 mA (+) Flow Signal Output
- 15 Chassis Ground

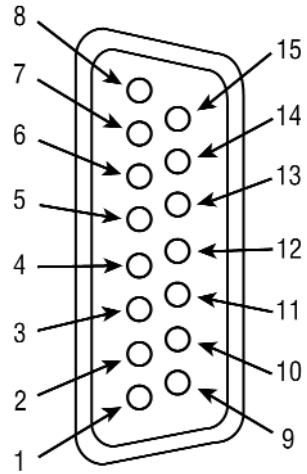

1 & 2	0-5 VDC OUTPUT	5 & 7	+12 VDC (+24 VDC*) POWER SUPPLY
3 & 4	PURGE	8 & 10	0-5 VDC OR 4-20 mA REMOTE SETPOINT
3 & 12	VALVE OFF CONTROL	9 & 14	4-20 mA OUTPUT
5 & 13	AUXILIARY +12 VDC (+24 VDC*) POWER OUTPUT (FOR LOADS <100 mA)	10 & 11	+5 VDC CONTROL SOURCE

FIGURE 2-1 GFC 15-PIN “D” CONNECTOR CONFIGURATION

*+24 VDC power supply configuration is optional for only GFC17/37/47 models.



WARNING: DO NOT CONNECT 24Vdc POWER SUPPLY UNLESS YOUR GFC CONTROLLER WAS ORDERED AND CONFIGURED FOR 24Vdc.

Important Notes:

In general, “D” Connector numbering patterns are standardized. There are, however, some connectors with nonconforming patterns and the numbering sequence on your mating connector may or may not coincide with the numbering sequence shown in our pin configuration table above. It is imperative that you match the appropriate wires in accordance with the correct sequence regardless of the particular numbers displayed on your mating connector.

Power must be turned OFF when connecting or disconnecting any cables in the system.

The power input is protected by a 1600mA M (medium time-lag) resettable fuse. If a shorting condition or polarity reversal occurs, the fuse will cut power to the flow transducer circuit. Disconnect the power to the unit, remove the faulty condition, and reconnect the power. The fuse will reset once the faculty condition has been removed.

Use of the GFC flow transducer in a manner other than that specified in this manual or in writing from Aalborg®, may impair the protection provided by the equipment.

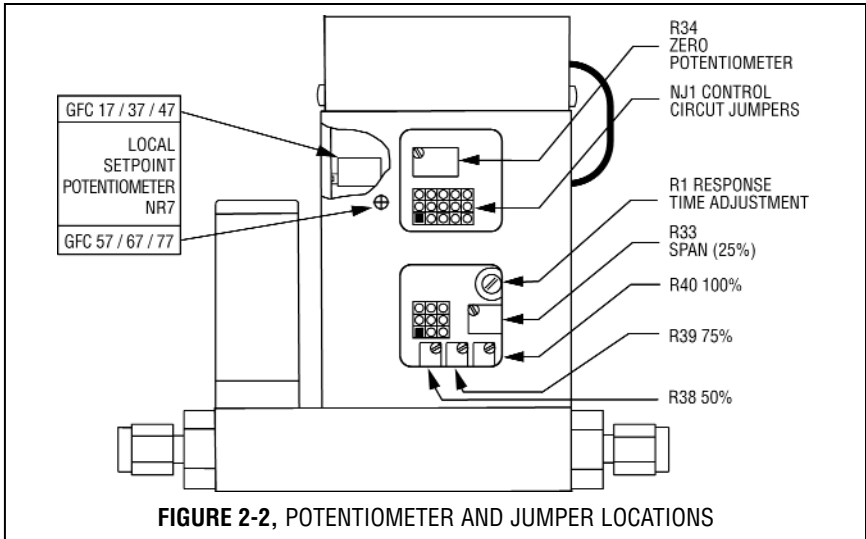

FIGURE 2-2, POTENTIOMETER AND JUMPER LOCATIONS

2.2.1 Valve Control Configuration

There are three basic valve control options.

- (a) LOCAL or REMOTE control.
- (b) 0 to 5 VDC or 4 to 20 mA setpoint signal -
 ***Note:** this only applies for the REMOTE control configuration;
- (c) 2% cutoff active or not active. **Note:** 2% cutoff not available for GFC 57/67/77.

When active, the 2% cutoff will shut off the power to the valve when a setpoint of less than 2% of the full scale flow range is set. Figure 2-2 shows the jumper configurations for the three basic valve control options.

The factory default jumper settings are: LOCAL control, 2% cutoff off, and 0 to 5 VDC.

FUNCTION	NJ1A	NJ1B	NJ1C	NJ1D	NJ1E
0 to 5 VDC	2 - 3	5 - 6	8 - 9		
4 to 20 mA	1 - 2	4 - 5	7 - 8		
local				11 - 12	
remote				10 - 11	
2% cutoff on					13 - 14
2% cutoff off					14 - 15



FIGURE 2-3, VALVE CONTROL CONFIGURATION JUMPERS

2.2.2 Remote LCD Readouts

GFC Mass Flow Controllers are available with optional remote reading LCD displays supplied with a three foot long wire to accommodate most applications. This configuration includes the upper block element which serves as the LCD readout mounting. Special lengths of remote extension wiring (up to 9.5 feet [3 meters]) are available on request.

2.2.3 Panel Mounting Readouts

Another option for the GFC Mass Flow Controller is the Panel Mounting Remote Readout.

In this configuration the LCD readout is supplied with a three foot long extension wire, and no aluminum housing around the LCD. The LCD readout for panel mounting includes a bezel with two plastic screws which conveniently fit into a rectangular cut-out for panel mounting (see Figure 2-3).

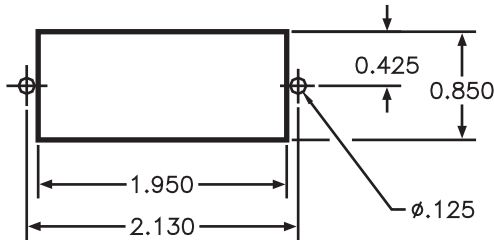

FIGURE 2-3 CUTOUT DIMENSIONS FOR LCD PANEL MOUNTING

3. PRINCIPLE OF OPERATION

The stream of gas entering the Mass Flow transducer is split by shunting a small portion of the flow through a capillary stainless steel sensor tube. The remainder of the gas flows through the primary flow conduit. The geometry of the primary conduit and the sensor tube are designed to ensure laminar flow in each branch. According to principles of fluid dynamics flow rates of gas in two properly sized laminar flow conduits are related to one another. Therefore, the flow rates measured in the sensor tube are directly proportional to the total flow through the transducer.

In order to sense the flow in the sensor tube, heat flux is introduced at two sections of the sensor tube by means of precision wound heater-sensor coils. Heat is transferred through the thin wall of the sensor tube to the gas flowing inside. As gas flow takes place heat is carried by the gas stream from the upstream coil to the downstream coil windings. The resultant temperature dependent resistance differential is detected electronically. The measured gradient at the sensor windings is linearly proportional to the instantaneous rate of flow taking place.

An output signal is generated that is a function of the amount of heat carried by the gases to indicate mass-molecular based flow rates.

GFC Mass Flow Controller models GFC17/37/47 also incorporate a proportionating solenoid valve and models GFC57/67/77 a motorized valve. The closed loop control circuit of the GFC continuously compares the mass flow output with the selected flow rate. Deviations from the setpoint are corrected by compensating valve adjustments, thus maintaining the desired flow parameters.

4. SPECIFICATIONS

FLOW MEDIUM: Please note that GFC Mass Flow Controllers are designed to work with clean gases only. Never try to meter or control flow rates of liquids.

CALIBRATIONS: Supplied at Standard Conditions (14.7 psia and 70° F), or Normal Conditions (0 °C and 1.01 bar abs) unless otherwise requested or stated.

ENVIRONMENTAL (per IEC 664): Installation Level II; Pollution Degree II.

ACCURACY:

ACCURACY % FS				OPTIONAL ENHANCED ACCURACY % FS			
MODEL	GFC 17, 37	GFC 47, 57, 67, 77		MODEL	GFC 17	GFC 37, 47, 57, 67, 77	
FLOW RANGE	2.5-100%	20-100%	0-20%	FLOW RANGE	2.5-100%	20-100%	0-20%
ACCURACY	±1.5%	±1.5%	±3%	ACCURACY	±1%	±1%	REF DATA with ±1%

REPEATABILITY: ±0.5% of full scale.

TEMPERATURE COEFFICIENT: 0.15% of full scale/ °C.

PRESSURE COEFFICIENT: 0.01% of full scale/psi (0.07 bar).

RESPONSE TIME: **GFC17:** 300ms time constant; approximately 1 second to within ±2% of set flow rate for 25% to 100% of full scale flow.

GFC 37/47: 600ms time constant; approximately 2 seconds to within ±2% of set flow rate for 25% to 100% of full scale flow.

GFC 57/67/77: 1800ms time constant; approximately 5 seconds to within ± 2% of set flow rate for 25% to 100% of full scale flow.

MAX GAS PRESSURE: 1000 psig (69 bars) 10, 50 and 100 L/min; 500 psig (34.5 bars) optimum pressure is 20 psig (1.4 bars).

TURNDOWN RATIO: 40:1.

MAX DIFFERENTIAL PRESSURE: 50 psid (345 kPa).

GAS TEMPERATURE: 32 °F to 122 °F (0 °C to 50 °C).

AMBIENT TEMPERATURE:14 °F to 122 °F (-10 °C to 50 °C).

GAS RELATIVE HUMIDITY: Up to 70%.

MAXIMUM INTERNAL LEAK: 0.5% FS.

LEAK INTEGRITY: 1×10^{-7} sccs He max to the outside environment.

ATTITUDE SENSITIVITY: No greater than ± 15 degree rotation from horizontal. Standard calibration is in horizontal position.

OUTPUT SIGNALS: Linear 0 to 5 VDC (1000Ω minimum load impedance) and 4 to 20 mA (0 to 500Ω loop resistance); 20 mV peak to peak max noise for GFC 17/37/47 and 100 mV peak to peak max noise for GFC 57/67/77.

COMMAND SIGNAL: Analog 0 to 5 VDC (100 K minimum input impedance) or 4 to 20 mA (250Ω input impedance).

Contact your distributor or Aalborg® for optional RS232 or IEEE488 interfaces.

TRANSDUCER INPUT POWER: +12 VDC, 800 mA maximum; GFC17/37/47 have an OPTION of +24 VDC, 650 mA maximum - **IF SPECIFIED AT TIME OF ORDERING AND CONFIGURED ACCORDINGLY.**

WETTED MATERIALS:

GFC17/37/47/57/67/77: Anodized aluminum, brass, 416 Stainless Steel and 316 stainless steel with VITON® O-rings seals; BUNA-N®, EPR or KALREZ® O-rings are optional.

GFC17S/37S/47S/57S/67S/77S: 416 Stainless Steel and 316 stainless steel with VITON® O-rings seals; BUNA-N®, EPR or KALREZ O-rings are optional.

Aalborg® makes no expressed or implied guarantees of corrosion resistance of mass flow meters as pertains to different flow media reacting with components of meters. It is the customers sole responsibility to select the model suitable for a particular gas based on the fluid contacting (wetted) materials offered in the different models.

CONNECTIONS:

GFC 17 and 37: 1/4" compression fittings. **Optional:** 6mm compression, 1/4" VCR®, 3/8" or 1/8" compression fittings.

GFC 47: 3/8" compression fittings.

GFC 57 3/8" compression fittings.

GFC 67: 1/2" compression fittings.

GFC 77: 3/4" FNPT fittings. **Optional:** 3/4" compression fittings.

LCD DISPLAY: 3½ digit LCD (maximum viewable digits "1999"), 0.5 inch high characters. On GFC171, GFC371, GFC471, GFC571, GFC671, GFC771 aluminum or stainless steel models the LCD display is built into the upper block element and may be tilted over 90 degrees for optimal viewing comfort. Remote or panel mounting remote reading is optional.

Standard readings are in direct engineering units for the given gas and flow rate (i.e. liters/minute [slpm], standard cubic centimeters/minute [sccm], standard cubic feet/hour [scfh], etc.). 0 to 100% LCD calibration scaling is available upon request at time of order. Contact your distributor or Aalborg® when non-standard display settings are desired.

TRANSDUCER INTERFACE CABLE: Optional shielded cable is available mating to the GFC transducer 15-pin "D" connector.

4.1 CE Compliance

GFC Mass Flow Controllers are in compliance with CE test standards stated below:

EMC Compliance with 89/336/EEC as amended; Emission Standard: EN 55011:1991, Group 1, Class B Immunity Standard: EN 55082-1:1992

4.2 Flow Capacities

TABLE I GFC 17 LOW FLOW MASS FLOW CONTROLLER*

MODEL	CODE	mL/min [N ₂]	CODE	liters/min [N ₂]
17	01	10	07	1
	02	20	08	2
	03	50	09	5
	04	100	10	10
	05	200		
	06	500		

TABLE II GFC 37 MEDIUM FLOW MASS FLOW CONTROLLER*

MODEL	CODE	liters/min [N ₂]
37	11	15
	30	20
	31	30
	32	40
	33	50

TABLE III GFC 47/57/67/77 HIGH FLOW MASS FLOW CONTROLLER*

MODEL	CODE	liters/min [N ₂]
47	40	60
	41	80
	42	100
57	50	200
67	60	500
77	70	1000

*Flow rates are stated for Nitrogen at STP conditions [i.e. 70 °F (21.1 °C) at 1 atm]. For other gases use the K factor as a multiplier from APPENDIX 2.

TABLE IV PRESSURE DROPS

MODEL	FLOW RATE [liters/min]	MAXIMUM PRESSURE DROP		
		[mm H ₂ O]	[psid]	[mbar]
GFC 17	UP to 10	720	1.06	75
GFC 37	15	2630	3.87	266
	20	1360	2.00	138
	30	2380	3.50	241
	40	3740	5.50	379
	50	5440	8.00	551
GFC 47	60	7480	11.00	758
	100	12850	18.89	1302
GFC 57	200	7031	10.00	690
GFC 67	500	8437	12.00	827
GFC 77	1000	10547	15.00	1034

5. OPERATING INSTRUCTIONS

5.1 Preparation and Warm Up

It is assumed that the Mass Flow Controller has been correctly installed and thoroughly leak tested as described in section (2). Shut the flow source OFF. Apply power to the unit via the 15-pin "D" connector. Use a power supply that is between +12 and +15 VDC with at least 800 mA current capacity (or optionally, for models GFC17/37/47 only, +24 VDC 650 mA). Allow the Mass Flow Controller to warm-up for at least 15 minutes.

During initial powering of the GFC transducer, the flow output signal will be indicating a higher than usual output. This is indication that the GFC transducer has not yet attained its minimum operating temperature. This condition will automatically cancel within a few minutes and the transducer should eventually zero.

If after the 15 minutes warm-up period, the display still indicates a reading of less than ± 3.0 % of F.S., readjust the ZERO potentiometer [R34] through the access window. Before zero adjustment temporarily disconnect the gas source, to ensure that no seepage or leak occurs in to the meter.

GFC 17/37/47 CAUTION



CAUTION: If the valve is left in the AUTO (control) or OPEN (PURGE) mode for an extended period of time, it may become warm or even hot to the touch. Use care in avoiding direct contact with the valve during operation.

Do not run GFC 17/37/47 models for extended periods of time with the valve in AUTO or PURGE mode without the flow of gas through the transducer. Doing so may result in up to 2% f.s. shift in calibration.

5.2 Flow Signal Output Readings

The flow signal output can be viewed on the LCD display, remote panel meter, digital multimeter, or other display device connected as shown in Figure 2.1.

If an LCD display has been ordered with the GFC, the observed reading is in direct engineering units, for example, 0 to 10 sccm or 0 to 100 slpm (0 to 100% indication is optional). Engineering units for a specific GFC are shown on the flow transducer's front label.

Analog output flow signals of 0 to 5 VDC and 4 to 20 mA are available at the appropriate pins of the 15-pin "D" connector at the side of the GFC transducer (see Figure 2-1).

Meter signal output is linearly proportional to the mass molecular flow rate of the gas being metered. The full scale range and gas for which your meter has been calibrated are shown on the flow transducer's front label.

Default calibration is performed for 0 to 5 VDC input/output signal. If 4-20 mA output signal is used for flow indication on the GFC, which was calibrated against 0 to 5 VDC input signal, the accuracy of the actual flow rate will be in the specified range ($\pm 1.5\%$) of full scale, but the total of the output reading may be in the range of $\pm 2.5\%$ of full scale. Optional calibration for 4-20 mA output signal is available upon request at time of order.

For optional RS232 or IEEE488 interfaces please contact your distributor or Aalborg®.

5.3 Swamping Condition

If a flow of more than 10% above the maximum flow rate of the Mass Flow Controller is taking place, a temporary condition known as "swamping" may occur. Readings of a "swamped" meter cannot be assumed to be either accurate or linear. Flow must be restored to below 110% of maximum meter range. Once flow rates are lowered to within calibrated range, the swamping condition will end. Operation of the meter above 110% of maximum calibrated flow may increase recovery time.

5.4 Setpoint Reference Signal

GFC flow controllers have built-in solenoid valves (GFC 17/37/47) or motorized valves (GFC 57/67/77), and allow the user to set the flow to any desired flow rate within the range of the particular model installed. The solenoid valve is normally closed (NC) when no power is applied.

The motorized valve can be in any position depending on the operation mode of the GFC during disconnecting of the power. For example if the motorized valve was left in the OPEN purge position after disconnecting power from the GFC it will be in the OPEN position. It is the customers responsibility to provide a solution to shut down the flow in case of a power outage. When power is applied to GFC 57/67/77 models, the valve automatically closes within the first ten seconds regardless of the set point and valve override signals.

Setpoints are controlled locally or remotely. Setpoints inputs respond to analog 0 to 5 VDC or 4 to 20 mA reference voltages (default jumper setting is 0 to 5 VDC). Voltage is a linear representation of 0 to 100% of the full scale mass flow rate. Response times to setpoint changes are 1 second (GFC 17), 2 seconds (GFC 37/47) and 5 seconds (GFC 57/67/77) within 2% of the final flow over 25 to 100% of full scale.

For LOCAL flow control, use the built-in setpoint potentiometer located at the same side as the solenoid valve of the GFC transducer. While applying flow to the transducer, adjust the setpoint with an insulated screwdriver until the flow reading is the same as the desired control point. [Display will only show actual instantaneous flow rates. There is no separate display for setpoints].

For REMOTE control of the GFC, an analog reference signal must be supplied. On pin [11] of the GFC transducer is a regulated and constant +5VDC output signal. This signal may be used in conjunction with a local setpoint potentiometer for flow setting.

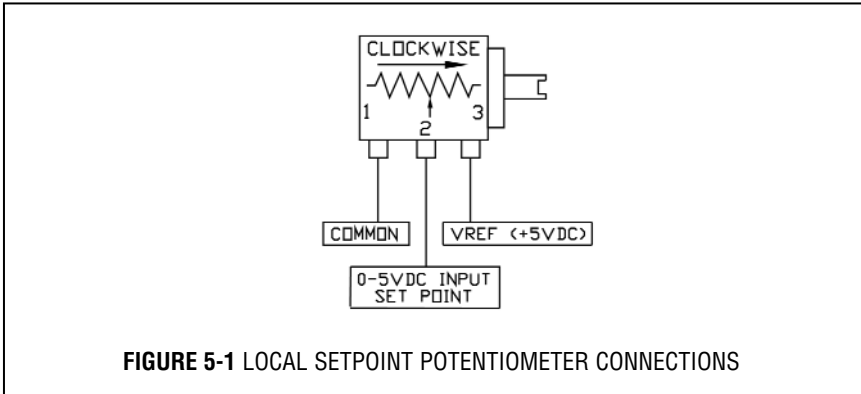

FIGURE 5-1 LOCAL SETPOINT POTENTIOMETER CONNECTIONS

It is recommended that a potentiometer between 5K to 100K ohm and capable of at least 10-turns or more for adjustment be used. Use the control potentiometer to command the percentage of flow desired.

Alternatively, a variable 0 to 5VDC or 4 to 20 mA analog signal may be applied directly to the SETPOINT and COMMON connections of the GFC transducer (see Figure 2-1). Be sure to apply the appropriate signal for the designated jumper settings.

5.5 Valve OFF Control (Open Collector NPN Compatible)

It may be necessary or desirable to set the flow and maintain that setting while being able to turn the flow control valve off and on again. Closing of the valve (without changing the setpoint adjustment) can be accomplished by connecting pin [12] of the 15-pin "D" connector to COMMON pin [3]. When pin [12] is connected to COMMON, the solenoid valve is not powered and therefore will remain normally closed regardless of the setpoint. The Motorized valve will be given the command to close indicated by a green light on top of the unit.

Conversely, when the connection is left open or pin [12] remains unconnected the valve remains active. The valve will remain active when the VALVE OFF pin remains “floating”. This feature is compatible with open collector NPN transistor switches, as found in DC output ports of programmable controllers and similar devices.

The simplest means for utilizing the VALVE OFF control feature, is to connect a toggle switch between the COMMON and VALVE OFF pins of the GFC transducer. Toggling the switch on and off will allow for activating and deactivating the solenoid valve.

5.6 Valve Test/Purge

At times, it may be necessary to purge the flow system with a neutralizing gas such as pure dry nitrogen. The GFC transducer is capable of a full open condition for the valve, regardless of setpoint conditions. Connecting the OPEN (PURGE) pin [3] to pin [4] on the 15-pin “D” connector will fully open the valve.

The Motorized Valve: Connect pins [3] and [4] to OPEN the motorized control valve. A red light on top of the valve will indicate an OPEN valve, normal for flow conditions.



Please Note: The motorized control valve stays OPEN even if power is no longer applied. To CLOSE the Motorized Control Valve, connect pins [3] and [12].

6. MAINTENANCE

6.1 Introduction

It is important that the Mass Flow Controller/Controller is used with clean, filtered gases only. Liquids may not be metered. Since the RTD sensor consists, in part, of a small capillary stainless steel tube, it is prone to occlusion due to impediments or gas crystallization. Other flow passages are also easily obstructed. Therefore, great care must be exercised to avoid the introduction of any potential flow impediment. To protect the instrument a 50 micron (GFC17) or 60 micron(GFC37/47) filter is built into the inlet of the flow transducer. The filter screen and the flow paths may require occasional cleaning as described below. There is no other recommended maintenance required. It is good practice, however, to keep the meter away from vibration, hot or corrosive environments and excessive RF or magnetic interference.

If periodic calibrations are required they should be performed by qualified personnel and calibrating instruments, as described in section (7). It is recommended that units are returned to Aalborg® for repair service and calibration.



CAUTION: TO PROTECT SERVICING PERSONNEL IT IS MANDATORY THAT ANY INSTRUMENT BEING SERVICED IS COMPLETELY PURGED AND NEUTRALIZED OF TOXIC, BACTERIOLOGICALLY INFECTED, CORROSIVE OR RADIOACTIVE CONTENTS.

6.2 Flow Path Cleaning

Inspect visually the flow paths at the inlet and outlet ends of the meter for any debris that may be clogging the flow through the meter. Remove debris carefully using tweezers and blowing low pressure clean air or Nitrogen from the inlet side. If the flow path is not unclogged, please return meter to Aalborg® for servicing.



Do not attempt to disassemble the sensor.
Disassembly will invalidate calibration.

6.2.1 Cleaning the Inlet Filter Screen in GFC17 Models

Unscrew the inlet compression fitting of meter. Note that the Restrictor Flow Element (RFE) is connected to the inlet fitting.

The Restrictor Flow Element (RFE) is a precision flow divider inside the transducer, which splits the inlet gas flow by a fixed ratio to the sensor and main flow paths. The particular RFE used in a given Mass Flow Controller depends on the gas and flow range of the instrument.

Carefully disassemble the RFE from the inlet connection. The 50 micron filter screen will now become visible. Push the screen out through the inlet fitting. Clean or replace each of the removed parts as necessary. If alcohol is used for cleaning, allow time for drying before re-assembling.

Carefully re-install the RFE and inlet fitting, avoiding any twisting and deforming the RFE. Be sure that no dust has collected on the O-ring seal.



Note: Over tightening will deform and render the RFE defective.

It is advisable that at least one calibration point be checked after re installing the inlet fitting - see section (7).



IT IS NOT RECOMMENDED TO ATTEMPT TO DISASSEMBLE,
OR REPAIR GFC37, GFC47, GFC57, GFC67 AND GFC77 MODELS.
DISASSEMBLY NECESSITATES RE-CALIBRATION.

6.2.2 Valve Maintenance for GFC17/37/47 Models

The solenoid valve consists of 316 and 416 stainless steel, and VITON® (or optional EPR or KALREZ®) O-rings and seal materials. No regular maintenance is required except for periodic cleaning.

It is advisable that at least one calibration point be checked after re-installing the inlet fitting - see section (7).

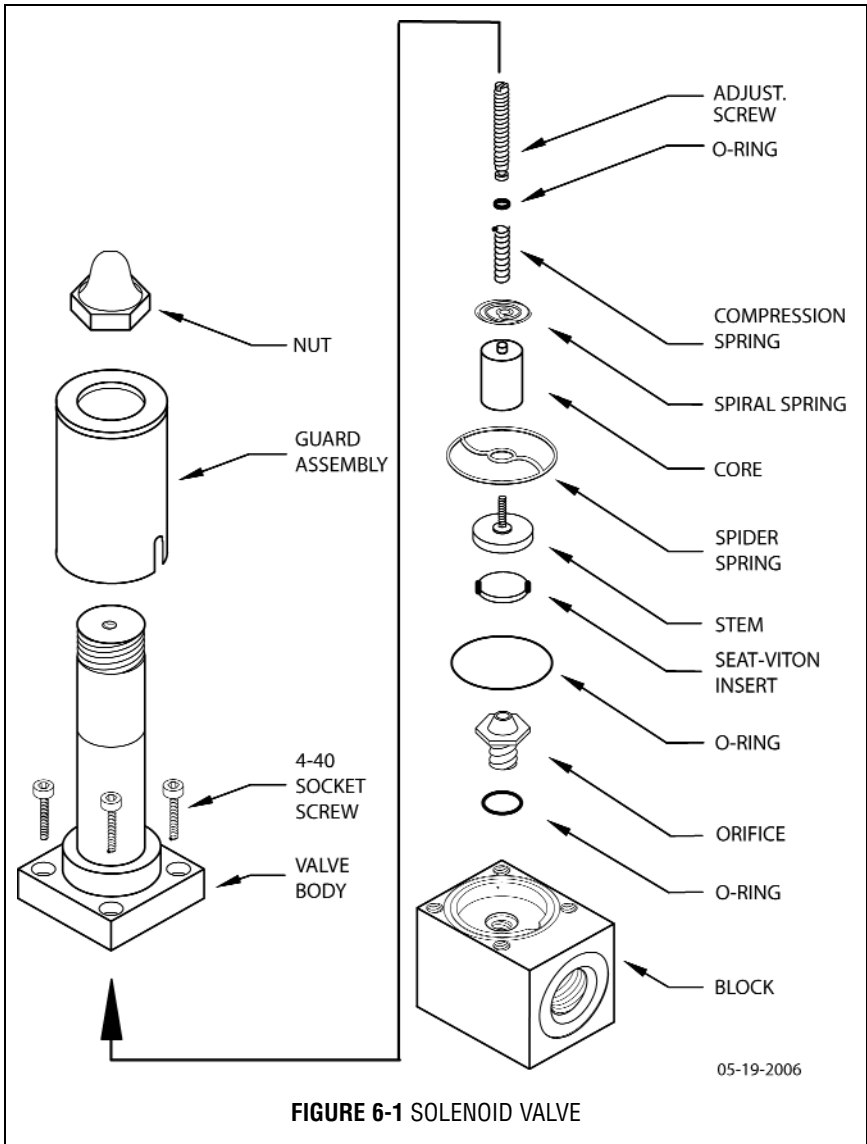

FIGURE 6-1 SOLENOID VALVE

Various corrosive gases may demand more frequent replacement of VITON® O-rings and seals inside the valve. Be sure to use an elastomer material, appropriate for your specific gas application. Contact your distributor or Aalborg® for optional sealing materials available.

Set the GFC into PURGE mode (see Figure 2-1), and attempt to flush through with a clean, filtered, and neutral gas such as nitrogen. [Another option for fully opening the valve is to remove the plastic cap on top of the valve, and turning the set screw counterclockwise until it stops. See section 7.3 for valve adjustment, to return the valve to functional use.]

7. CALIBRATION PROCEDURES



NOTE: Removal of the factory installed calibration seals and/or any adjustments made to the meter, as described in this section, will void any calibration warranty applicable.

7.1 Flow Calibration

Aalborg® Instruments' Flow Calibration Laboratory offers professional calibration support for Mass Flow Meters and Controllers, using precision calibrators under strictly controlled conditions. NIST traceable calibrations are available. Calibrations can also be performed by customers using available certified standards.

Factory calibrations are performed using state of the art NIST traceable precision volumetric calibrators.

Calibrations are performed using dry nitrogen gas. Calibration can then be corrected to the appropriate gas desired based on relative correction [K] factors shown in the gas factor table - see Appendix 2. A reference gas, other than nitrogen, may be used to approximate the flow characteristics of certain gases closer. This practice is recommended when a reference gas is found with thermodynamic properties similar to the actual gas under consideration. The appropriate relative correction factor should be recalculated - see section (9).

It is standard practice to calibrate Mass Flow Controllers with dry nitrogen gas. It is best to calibrate the GFC transducers to actual operating conditions. Specific gas calibrations of non-toxic and non-corrosive gases are available at specific conditions. Please contact your distributor or Aalborg® for a price quotation.

It is recommended that a flow calibrator of at least four times better collective accuracy than that of the Mass Flow Meter/Controller to be calibrated be used. Equipment required for calibration includes a flow calibration standard and a certified high sensitivity multimeter (which together have a collective accuracy of $\pm 0.25\%$ or better), an insulated (plastic) screwdriver, a flow regulator (example: metering needle valve) installed upstream from the Mass Flow Controller and a pressure regulated source of dry filtered nitrogen gas (or other suitable reference gas).

The gas and ambient temperature, as well as inlet and outlet pressure conditions should be set up in accordance with actual operating conditions.

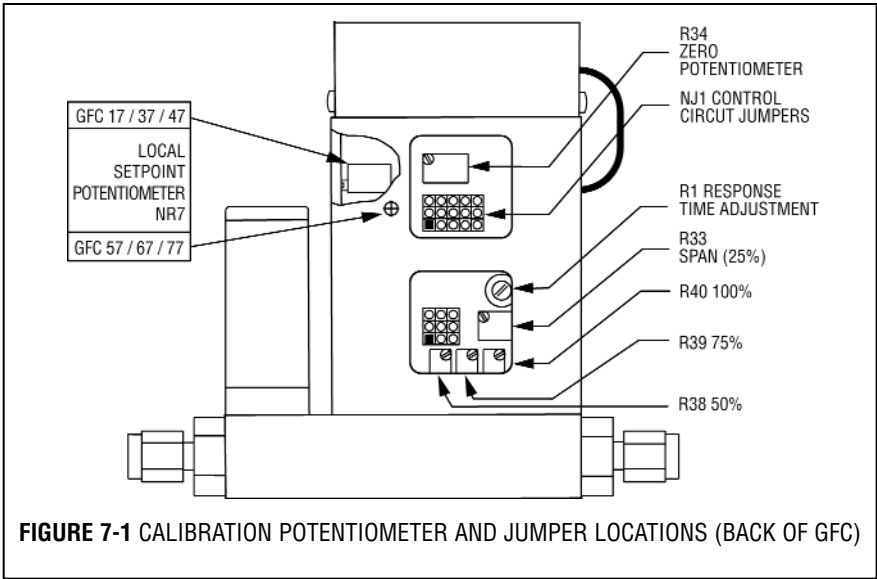

7.2 Calibration of GFC Mass Flow Controllers

All adjustments in this section are made from the outside of the meter, there is no need to disassemble any part of the instrument.

GFC Mass Flow Controllers may be field recalibrated/checked for the same range they were originally factory calibrated for. When linearity adjustment is needed, or flow range changes are being made proceed to step 7.2.4. Flow range changes may require a different Restrictor Flow Element (RFE). Additionally, a different Solenoid Valve Orifice may also be required (see Table VI). Consult your distributor or Aalborg® for more information.

7.2.1 Connections and Initial Warm Up

At the 15-pin “D” connector of the GFC transducer, connect the multimeter to output pins [1] and [2] for 0 to 5 VDC (or pins [9] and [14] for 4 to 20 mA) - (see Figure 2-1).

When using a remote setpoint for flow control, the appropriate reference signal should also be connected to the 15-pin “D” connector at pins [8] and [10] - (see Figure 2-1). Power up the Mass Flow Controller for at least 30 minutes prior to commencing the calibration procedure.

7.2.2 ZERO Adjustment

Shut off the flow of gas into the Mass Flow Controller. To ensure that no seepage or leak occurs into the meter, temporarily disconnect the gas source.

Using the multimeter and the insulated screwdriver, adjust the ZERO potentiometer [R34] through the access window for 0 VDC (or 4 mA respectively) at zero flow.

7.2.3 SPAN Adjustment

Reconnect the gas source. Adjust the control setpoint to 100% of full scale flow. Check the flow rate indicated against the flow calibrator. If the deviation is less than $\pm 10\%$ of full scale reading, correct the SPAN potentiometer [R33] setting by using the insulated screwdriver through the access window, to eliminate any deviation. If the deviation is larger than $\pm 10\%$ of full scale reading, a defective condition may be present.

LIKELY REASONS FOR A MALFUNCTIONING SIGNAL MAY BE:

- ✓ Occluded or contaminated sensor tube.
- ✓ Leaking condition in the GFC transducer or the gas line and fittings.
- ✓ For gases other than nitrogen, recheck appropriate "K" factor from Gas Factor Table.
- ✓ Temperature and/or pressure correction errors.

See also section (8) TROUBLESHOOTING. If after attempting to remedy the above conditions, a malfunction still persists, return the meter for factory service, see section (1).

At this point the calibration is complete. However, it is advisable that several additional points between 0 and 100%, such as 25%, 50%, and 75% flow be checked. If discrepancies are found, proceed to step 7.2.4 for Linearity Adjustment.

7.2.4 Linearity Adjustment

All adjustments in this section are made from the outside of the meter, there is no need to disassemble any part of the instrument.

7.2.4.1 Disable Solenoid Valve in GFC17/37/47 Models

Set the valve into PURGE mode. This step essentially bypasses the flow control properties of the transducer. The unit will now act as a Mass Flow Meter.

7.2.4.2 Open Motorized Valve in GFC57/67/77 Models

Set the valve to PURGE mode by connecting pin [4] to pin [3], at the 15 pin D-connector.



CAUTION: FOR GFC17/37/47- If the valve is left in the AUTO (control) or OPEN (PURGE) mode for an extended period of time, it may become warm or even hot to the touch. Use care in avoiding direct contact with the valve during operation.

7.2.5 Connections and Initial Warm Up

Connect the multimeter to output pins [1] and [2] for 0 to 5 VDC (or pins [9] and [14] for 4 to 20 mA) of the 15-pin “D” connector - (see Figure 2-1).

If calibration to a new flow range or different gas is being performed, it may be necessary to remove any jumpers at J1A, J1B, and J1C before beginning linearizing procedure.

Power up the Mass Flow Controller for at least 30 minutes prior to commencing the calibration procedure.

7.2.6 ZERO Adjustment

Shut off the flow of gas into the Mass Flow Controller. To ensure that no seepage or leak occurs into the meter, it is good practice to temporarily disconnect the gas source.

Using the multimeter and the insulated screwdriver, adjust the ZERO potentiometer [R34] through the access window for 0 VDC (or 4 mA respectively) at zero flow.

7.2.7 25% Flow Adjustment

Reconnect the gas source. Using the flow regulator, adjust the flow rate to 25% of full scale flow. Check the flow rate indicated against the flow calibrator. Adjust the setting for potentiometer [R33] by using the insulated screwdriver through the access window, until the output of the flow meter reads 1.25VDC \pm 63mV (or 8mA \pm 0.25mA).

LINEARIZER FUNCTION	J1A (50%)	J1B (75%)	J1C (100%)
Decrease	1 - 2	4 - 5	7 - 8
Increase	2 - 3	5 - 6	8 - 9

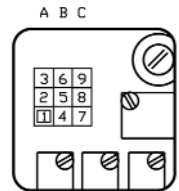

FIGURE 7-2 CALIBRATION POTENTIOMETER AND JUMPERS

7.2.8 50% Flow Adjustment

Using the flow regulator, increase the flow rate to 50% of full scale flow. Check the flow rate indicated against the flow calibrator. The output of the flow meter should read 2.50VDC \pm 63mV (or 12mA \pm 0.25mA). If the reading is outside of that range, place the jumper at [J1A] as appropriate to increase or decrease the signal. Adjust the setting for potentiometer [R38] by using the insulated screwdriver through the access window, until reading is within specification.

7.2.9 75% Flow Adjustment

Using the flow regulator, increase the flow rate to 75% of full scale flow. Check the flow rate indicated against the flow calibrator. The output of the flow meter should read 3.75VDC \pm 63mV (or 16mA \pm 0.25mA). If the reading is outside of that range, place the jumper at [J1B] as appropriate to increase or decrease the signal. Adjust the setting for potentiometer [R39] by using the insulated screwdriver through the access window, until reading is within specification.

7.2.10 100% Flow Adjustment

Using the flow regulator, increase the flow rate to 100% of full scale flow. Check the flow rate indicated against the flow calibrator. The output of the flow meter should read 5.00VDC \pm 63mV (or 20mA \pm 0.25mA). If the reading is outside of that range, place the jumper at [J1C] as appropriate to increase or decrease the signal. Adjust the setting for potentiometer [R40] by using the insulated screwdriver through the access window, until reading is within specification.

Repeat steps 7.2.7 to 7.2.10 at least once more.

7.2.11. VALVE ADJUSTMENT

7.2.11.1 Valve Adjustment for GFC17/37/47

Discontinue the PURGE mode (set valve for the closed position). Apply an inlet pressure of 5 psig, and atmospheric pressure at the outlet. If a small flow occurs, turn the set screw on top of the solenoid valve clockwise until the flow through the GFC just stops

7.2.11.2 Valve Adjustment for GFC 57/67/77

DO NOT adjust the motorized valve for GFC57/67/77.

The motorized valve for these models has been pre-adjusted at the factory.

7.2.12 Full Scale Flow Adjustment

Fully open the flow regulator upstream of the GFC. Increase the inlet pressure to 20 psig (25 psig for GFC47). Apply a +5.00 VDC (100% full scale flow) setpoint reference. Using the calibrator check the flow rate. If necessary, adjust R33 to match the desired full scale flow rate. [In control mode, turning R33 clockwise will decrease the flow. Conversely, turning R33 counterclockwise will increase the flow through the GFC.]

7.2.13 25% Flow Adjustment

Change the setpoint to 1.25 VDC to control at 25% of full scale flow. Check the flow rate indicated against the flow calibrator. If the flow rate is not within \pm 0.75% of full scale, re-adjust the setting for potentiometer [R33], until the flow output is correct.

7.2.14 50% Flow Adjustment

Change the setpoint to 2.50 VDC to control at 50% of full scale flow. Check the flow rate indicated against the flow calibrator. If the flow rate is not within $\pm 0.75\%$ of full scale, re-adjust the setting for potentiometer [R38], until the flow output is correct.

7.2.15 75% Flow Adjustment

Change the setpoint to 3.75 VDC to control at 75% of full scale flow. Check the flow rate indicated against the flow calibrator. If the flow rate is not within $\pm 0.75\%$ of full scale, re-adjust the setting for potentiometer [R39], until the flow output is correct.

7.2.16 100% Flow Adjustment

Change the setpoint to 5.00 VDC to control at 100% of full scale flow. Check the flow rate indicated against the flow calibrator. If the flow rate is not within $\pm 0.75\%$ of full scale, re-adjust the setting for potentiometer [R40], until the flow output is correct.

Repeat steps 7.2.13 to 7.2.16 at least once more.

TABLE II GFC SOLENOID VALVE ORIFICE SELECTION TABLE

ORIFICE PART NUMBER	FLOW RATE [N ₂]
OR.010	under 10 sccm
OR.020	10 to 1000 sccm
OR.040	1 to 5 slpm
OR.055	5 to 10 slpm
OR.063	10 to 15 slpm
OR.073	15 to 20 slpm
OR.094	20 to 50 slpm
OR.125	50 to 100 slpm

7.2.17 LCD Display Scaling

It may be desirable to re-scale the output reading on the LCD readout supplied with certain model GFC transducers. Re-calibration for a new flow range or different engineering units are two examples of when this may be necessary.

7.2.17.1 Access LCD Display Circuit

Carefully remove the LCD from the GFC or panel mounted surface. Remove the aluminum housing on the side of the connection cable. Slide the LCD assembly out of the aluminum housing.

7.2.17.2 Adjust Scaling

Using a digital multimeter connected to either the 0 to 5 VDC or 4 to 20 mA signal at the 15-pin “D” connector, set the flow rate on the GFC to full scale flow (5 VDC or 20mA). Maintain full scale flow, and adjust the potentiometer [R3] on the LCD printed circuit board to desired full scale flow reading.

7.2.17.3 Change Decimal Point

To change the decimal place on the LCD display readout, simply move the jumper to the appropriate location on the [8] pin header block. The numbers are printed to the side of the connections. Do not attempt to place more than one jumper for decimal setting.

JUMPER POSITION	MAXIMUM SCALABLE DISPLAY READING
“0”	1999
“1”	199.9
“2”	19.99
“3”	1.999

8. TROUBLESHOOTING

8.1 Common Conditions

Your Mass Flow Controller was thoroughly checked at numerous quality control points during and after manufacturing and assembly operations. It was calibrated in accordance to your desired flow and pressure conditions for a given gas or a mixture of gases.

It was carefully packed to prevent damage during shipment. Should you feel that the instrument is not functioning properly please check for the following common conditions first:

- ✓ Are all cables connected correctly?
- ✓ Are there any leaks in the installation?
- ✓ Is the power supply correctly selected according to requirements?
When several meters are used a power supply with appropriate current rating should be selected.
- ✓ Were the connector pinouts matched properly? When interchanging with other manufacturers' equipment, cables and connectors must be carefully wired for correct pin configurations.
- ✓ Is the pressure differential across the instrument sufficient?

8.2 Troubleshooting Guide

INDICATION	LIKELY REASON	REMEDY
lack of reading or output	power supply off	check connection of power supply
	fuse blown	disconnect transducer from power supply; remove the shorting condition or check polarities; fuse resets automatically
	filter screen obstructed at inlet	flush clean or disassemble to remove impediments or replace
	occluded sensor tube	flush clean or disassemble to remove impediments or return to factory for replacement
	pc board defect	return to factory for replacement
	valve adjustment wrong	re-adjust valve (section 7.2.4)
flow reading does not coincide with the setpoint	inadequate gas pressure	apply appropriate gas pressure
	filter screen obstructed at inlet	flush clean or disassemble to remove impediments or replace
	ground loop	signal and power supply commons are different
no response to setpoint	inadequate gas pressure	apply appropriate gas pressure
	cable or connector malfunction	check cables and all connections or replace
	setpoint is too low (<2% of full scale)	re adjust setpoint or disable 2% cutoff feature (section 2.2)
	valve adjustment wrong	re-adjust valve (section 7.2.4)
unstable or no zero reading	gas leak	locate and correct
	pc board defective	return to factory for replacement
full scale output at "no flow" condition or with valve closed	defective sensor	return to factory for replacement
	gas leak	locate and repair

INDICATION	LIKELY REASON	REMEDY
calibration off	gas metered is not the same as what meter was calibrated for	use matched calibration
	composition of gas changed	see K factor tables in APPENDIX 2
	gas leak	locate and correct
	pc board defective	return to factory for replacement
	RFE dirty	flush clean or disassemble to remove impediments
	occluded sensor tube	flush clean or disassemble to remove impediments or return to factory for replacement
	filter screen obstructed at inlet	flush clean or disassemble to remove impediments or replace
	transducer is not mounted properly	check for any tilt or change in the mounting of the transducer; generally, units are calibrated for horizontal installation (relative to the sensor tube)
GFC valve does not work in open position	incorrect valve adjustment	re-adjust valve (section 7.2.4)
	pc board defect	return to factory for replacement
	cable or connectors malfunction	check cable and connectors or replace
	differential pressure too high	decrease pressure to correct level
	insufficient inlet pressure	adjust appropriately
GFC valve does not work in closed position	incorrect valve adjustment	re-adjust valve (section 7.2.4)
	pc board defect	return to factory for replacement
	cable or connectors malfunction	check cable and connectors or replace
	orifice obstructed	disassemble to remove impediments or return to factory

For best results it is recommended that instruments are returned to the factory for servicing. See section 1.3 for return procedures.

8.3 Technical Assistance

Aalborg® Instruments will provide technical assistance over the phone to qualified repair personnel. Please call our Technical Assistance at 845-770-3000. Please have your Serial Number and Model Number ready when you call.

9. CALIBRATION CONVERSIONS FROM REFERENCE GASES

The calibration conversion incorporates the K factor. The K factor is derived from gas density and coefficient of specific heat. For diatomic gases:

$$K_{\text{gas}} = \frac{1}{d \times C_p}$$

where d = gas density (gram/liter)

C_p = coefficient of specific heat (cal/gram)

Note: in the above relationship that d and C_p are chosen at the same conditions (temperature, pressure).

If the flow range of a Mass Flow Controller remains unchanged, a relative K factor is used to relate the calibration of the actual gas to the reference gas.

$$K = \frac{Q_a}{Q_r} = \frac{K_a}{K_r}$$

where Q_a = mass flow rate of an actual gas (sccm)

Q_r = mass flow rate of a reference gas (sccm)

K_a = K factor of an actual gas

K_r = K factor of a reference gas

For example, if we want to know the flow rate of oxygen and wish to calibrate with nitrogen at 1000 SCCM, the flow rate of oxygen is:

$$Q_{O_2} = Q_a = Q_r \times K = 1000 \times 0.9926 = 992.6 \text{ sccm}$$

where K = relative K factor to reference gas (oxygen to nitrogen)

APPENDIX 1

COMPONENTS DIAGRAM

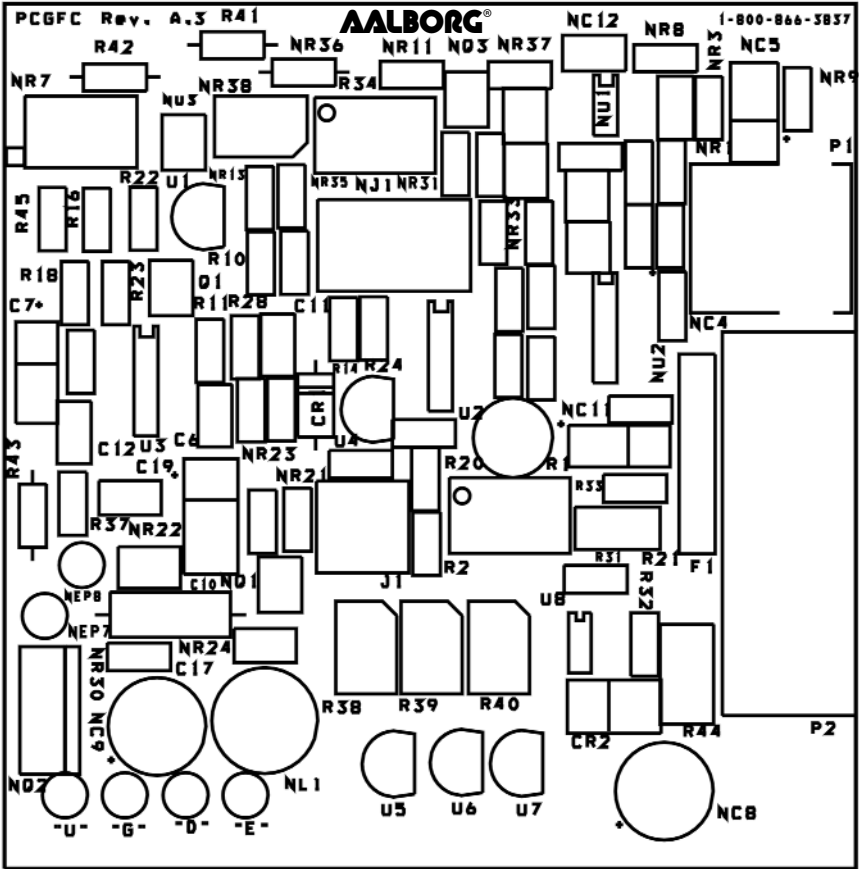

GFC METERING PC BOARD (TOP SIDE)

COMPONENTS DIAGRAM

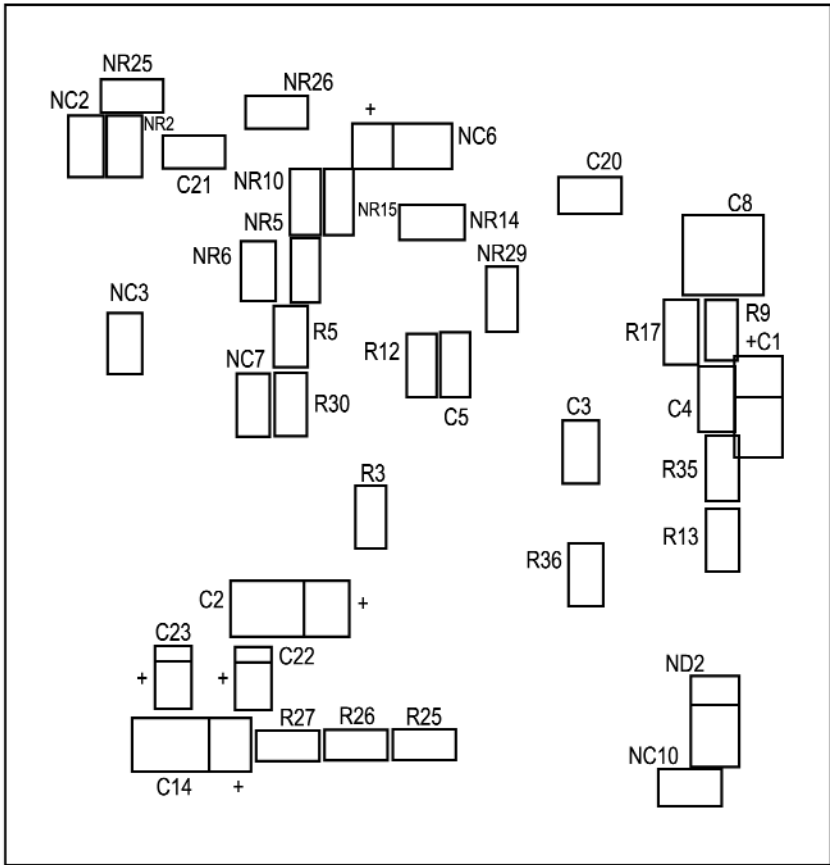

METERING PC BOARD (BOTTOM SIDE)

APPENDIX 2
GAS FACTOR TABLE (“K” FACTORS)

⚠ CAUTION: K-Factors at best are only an approximation. K factors should not be used in applications that require accuracy better than +/- 5 to 10%.

ACTUAL GAS	K FACTOR Relative to N ₂	Cp [Cal/g]	Density [g/l]
Acetylene C ₂ H ₂	.5829	.4036	1.162
Air	1.0000	.240	1.293
Allene (Propadiene) C ₃ H ₄	.4346	.352	1.787
Ammonia NH ₃	.7310	.492	.760
Argon Ar	1.4573	.1244	1.782
Argon AR-1 (>10 L/min)	1.205	.1244	1.782
Arsine AsH ₃	.6735	.1167	3.478
Boron Trichloride BCl ₃	.4089	.1279	5.227
Boron Trifluoride BF ₃	.5082	.1778	3.025
Bromine Br ₂	.8083	.0539	7.130
Boron Tribromide Br ₃	.38	.0647	11.18
Bromine PentaTrifluoride BrF ₅	.26	.1369	7.803
Bromine Trifluoride BrF ₃	.3855	.1161	6.108
Bromotrifluoromethane (Freon-13 B1) CBrF ₃	.3697	.1113	6.644
1,3-Butadiene C ₄ H ₆	.3224	.3514	2.413
Butane C ₄ H ₁₀	.2631	.4007	2.593
1-Butene C ₄ H ₈	.2994	.3648	2.503
2-Butene C ₄ H ₈ CIS	.324	.336	2.503
2-Butene C ₄ H ₈ TRANS	.291	.374	2.503
Carbon Dioxide CO ₂	.7382	.2016	1.964
Carbon Dioxide CO ₂ -1 (>10 L/min)	.658	.2016	1.964
Carbon Disulfide CS ₂	.6026	.1428	3.397
Carbon Monoxide CO	1.00	.2488	1.250
Carbon Tetrachloride CCl ₄	.31	.1655	6.860
Carbon Tetrafluoride (Freon-14)CF ₄	.42	.1654	3.926
Carbonyl Fluoride COF ₂	.5428	.1710	2.945
Carbonyl Sulfide COS	.6606	.1651	2.680
Chlorine Cl ₂	.86	.114	3.163
Chlorine Trifluoride ClF ₃	.4016	.1650	4.125
Chlorodifluoromethane (Freon-22)CHClF ₂	.4589	.1544	3.858
Chloroform CHCl ₃	.3912	.1309	5.326
Chloropentafluoroethane(Freon-115)C ₂ ClF ₅	.2418	.164	6.892
Chlorotrifluoromethane (Freon-13) CClF ₃	.3834	.153	4.660
CyanogenC ₂ N ₂	.61	.2613	2.322
CyanogenChloride ClCN	.6130	.1739	2.742
Cyclopropane C ₃ H ₅	.4584	.3177	1.877

ACTUAL GAS	K FACTOR Relative to N ₂	Cp [Cal/g]	Density [g/l]
Deuterium D ₂	1.00	1.722	1.799
Diborane B ₂ H ₆	.4357	.508	1.235
Dibromodifluoromethane CBr ₂ F ₂	.1947	.15	9.362
Dichlorodifluoromethane (Freon-12) CCl ₂ F ₂	.3538	.1432	5.395
Dichlorofluoromethane (Freon-21) CHCl ₂ F	.4252	.140	4.592
Dichloromethylsilane (CH ₃) ₂ SiCl ₂	.2522	.1882	5.758
Dichlorosilane SiH ₂ Cl ₂	.4044	.150	4.506
Dichlorotetrafluoroethane (Freon-114) C ₂ Cl ₂ F ₄	.2235	.1604	7.626
1,1-Difluoroethylene (Freon-1132A) C ₂ H ₂ F ₂	.4271	.224	2.857
Dimethylamine (CH ₃) ₂ NH	.3714	.366	2.011
Dimethyl Ether (CH ₃) ₂ O	.3896	.3414	2.055
2,2-Dimethylpropane C ₃ H ₁₂	.2170	.3914	3.219
Ethane C ₂ H ₆	.50	.420	1.342
Ethanol C ₂ H ₆ O	.3918	.3395	2.055
Ethyl Acetylene C ₄ H ₆	.3225	.3513	2.413
Ethyl Chloride C ₂ H ₅ Cl	.3891	.244	2.879
Ethylene C ₂ H ₄	.60	.365	1.251
Ethylene Oxide C ₂ H ₄ O	.5191	.268	1.965
Fluorine F ₂	.9784	.1873	1.695
Fluoroform (Freon-23) CHF ₃	.4967	.176	3.127
Freon-11 CCl ₃ F	.3287	.1357	6.129
Freon-12 CCl ₂ F ₂	.3538	.1432	5.395
Freon-13 CClF ₃	.3834	.153	4.660
Freon-13B1 CBrF ₃	.3697	.1113	6.644
Freon-14 CF ₄	.4210	.1654	3.926
Freon-21 CHCl ₂ F	.4252	.140	4.592
Freon-22 CHClF ₂	.4589	.1544	3.858
Freon-113 CCl ₂ CClF ₂	.2031	.161	8.360
Freon-114 C ₂ Cl ₂ F ₄	.2240	.160	7.626
Freon-115 C ₂ ClF ₅	.2418	.164	6.892
Freon-C318 C ₄ F ₈	.1760	.185	8.397
Germane GeH ₄	.5696	.1404	3.418
Germanium Tetrachloride GeCl ₄	.2668	.1071	9.565
Helium He	1.454	1.241	.1786
Helium He-1 (>50 L/min)	2.43	1.241	.1786
Helium He-2 (>10-50 L/min)	2.05	1.241	.1786
Hexafluoroethane C ₂ F ₆ (Freon-116)	.2421	.1834	6.157
Hexane C ₆ H ₁₄	.1792	.3968	3.845
Hydrogen H ₂ -1	1.0106	3.419	.0899
Hydrogen H ₂ -2 (>10-100 L)	1.35	3.419	.0899
Hydrogen H ₂ -3 (>100 L)	1.9	3.419	.0899

ACTUAL GAS	K FACTOR Relative to N ₂	Cp [Cal/g]	Density [g/l]
Hydrogen Bromide HBr	1.000	.0861	3.610
Hydrogen Chloride HCl	1.000	.1912	1.627
Hydrogen Cyanide HCN	.764	.3171	1.206
Hydrogen Fluoride HF	.9998	.3479	.893
Hydrogen Iodide HI	.9987	.0545	5.707
Hydrogen Selenide H ₂ Se	.7893	.1025	3.613
Hydrogen Sulfide H ₂ S	.80	.2397	1.520
Iodine Pentafluoride IF ₅	.2492	.1108	9.90
Isobutane CH(CH ₃) ₃	.27	.3872	3.593
Isobutylene C ₄ H ₆	.2951	.3701	2.503
Krypton Kr	1.453	.0593	3.739
Methane CH ₄	.7175	.5328	.715
Methane CH ₄ -1 (>10 L/min)	.75	.5328	.715
Methanol CH ₃	.5843	.3274	1.429
Methyl Acetylene C ₃ H ₄	.4313	.3547	1.787
Methyl Bromide CH ₂ Br	.5835	.1106	4.236
Methyl Chloride CH ₃ Cl	.6299	.1926	2.253
Methyl Fluoride CH ₃ F	.68	.3221	1.518
Methyl Mercaptan CH ₃ SH	.5180	.2459	2.146
Methyl Trichlorosilane (CH ₃)SiCl ₃	.2499	.164	6.669
Molybdenum Hexafluoride MoF ₆	.2126	.1373	9.366
Monoethylamine C ₂ H ₅ NH ₂	.3512	.387	2.011
Monomethylamine CH ₃ NH ₂	.51	.4343	1.386
Neon NE	1.46	.246	.900
Nitric Oxide NO	.990	.2328	1.339
Nitrogen N ₂	1.000	.2485	1.25
Nitrogen Dioxide NO ₂	.737	.1933	2.052
Nitrogen Trifluoride NF ₃	.4802	.1797	3.168
Nitrosyl Chloride NOCl	.6134	.1632	2.920
Nitrous Oxide N ₂ O	.7128	.2088	1.964
Octafluorocyclobutane (Freon-C318) C ₄ F ₈	.176	.185	8.397
Oxygen O ₂	.9926	.2193	1.427
Oxygen Difluoride OF ₂	.6337	.1917	2.406
Ozone	.446	.195	2.144
Pentaborane B ₅ H ₉	.2554	.38	2.816
Pentane C ₅ H ₁₂	.2134	.398	3.219
Perchloryl Fluoride ClO ₃ F	.3950	.1514	4.571
Perfluoropropane C ₃ F ₈	.174	.197	8.388
Phosgene COCl ₂	.4438	.1394	4.418
Phosphine PH ₃	.759	.2374	1.517

ACTUAL GAS	K FACTOR Relative to N ₂	Cp [Cal/g]	Density [g/l]
Phosphorous Oxychloride POCl ₃	.36	.1324	6.843
Phosphorous Pentafluoride PH ₅	.3021	.1610	5.620
Phosphorous Trichloride PCl ₃	.30	.1250	6.127
Propane C ₃ H ₈	.35	.399	1.967
Propylene C ₃ H ₆	.40	.366	1.877
Silane SiH ₄	.5982	.3189	1.433
Silicon Tetrachloride SiCl ₄	.284	.1270	7.580
Silicon Tetrafluoride SiF ₄	.3482	.1691	4.643
Sulfur Dioxide SO ₂	.69	.1488	2.858
Sulfur Hexafluoride SF ₆	.2635	.1592	6.516
Sulfuryl Fluoride SO ₂ F ₂	.3883	.1543	4.562
Tetrafluoroethane (Forane 134A) CF ₃ CH ₂ F	.5096	.127	4.224
Tetrafluorohydrazine N ₂ F ₄	.3237	.182	4.64
Trichlorofluoromethane (Freon-11) CCl ₃ F	.3287	.1357	6.129
Trichlorosilane SiHCl ₃	.3278	.1380	6.043
1,1,2-Trichloro-1,2,2 Trifluoroethane (Freon-113) CCl ₂ FCF ₂	.2031	.161	8.36
Triisobutyl Aluminum (C ₄ H ₉) ₃ Al	.0608	.508	8.848
Titanium Tetrachloride TiCl ₄	.2691	.120	8.465
Trichloro Ethylene C ₂ HCl ₃	.32	.163	5.95
Trimethylamine (CH ₃) ₃ N	.2792	.3710	2.639
Tungsten Hexafluoride WF ₆	.2541	.0810	13.28
Uranium Hexafluoride UF ₆	.1961	.0888	15.70
Vinyl Bromide CH ₂ CHBr	.4616	.1241	4.772
Vinyl Chloride CH ₂ CHCl	.48	.12054	2.788
Xenon Xe	1.44	.0378	5.858

APPENDIX 3

DIMENSIONAL DRAWINGS

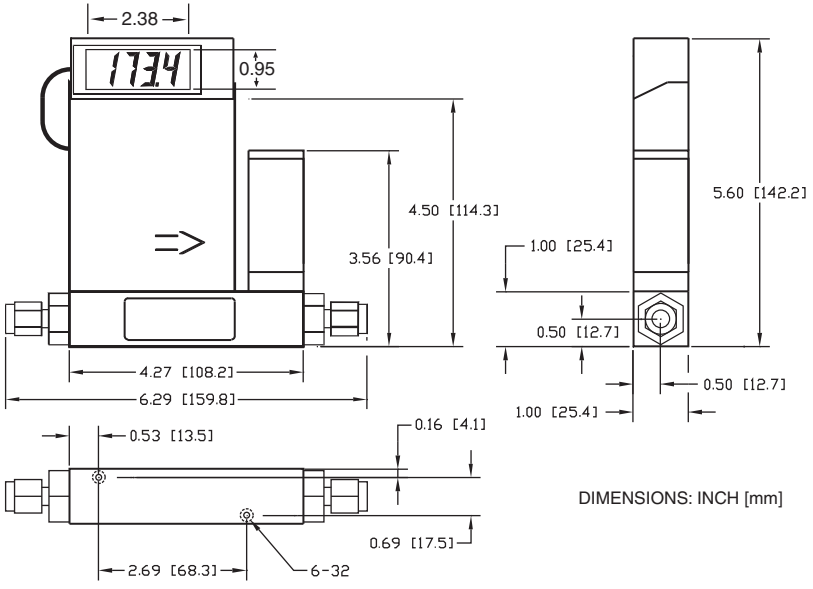

GFC17 MASS FLOW CONTROLLER

NOTE: Aalborg® reserves the right to change designs and dimensions at its sole discretion at any time without notice. For certified dimensions please contact Aalborg®.

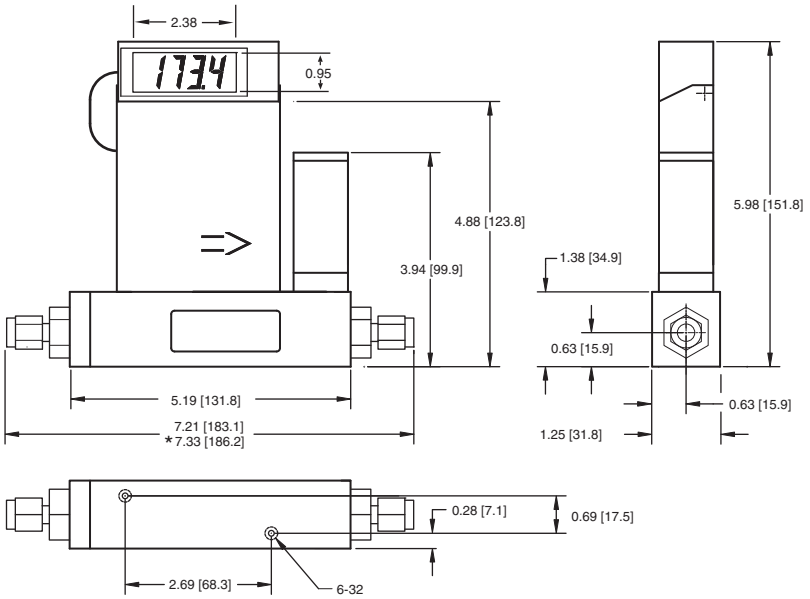

* FOR HIGH FLOW MASS FLOW CONTROLLER ONLY
 DIMENSIONS: INCH [mm]

GFC37/47 MASS FLOW CONTROLLER

NOTE: Aalborg® reserves the right to change designs and dimensions at its sole discretion at any time without notice. For certified dimensions please contact Aalborg®.

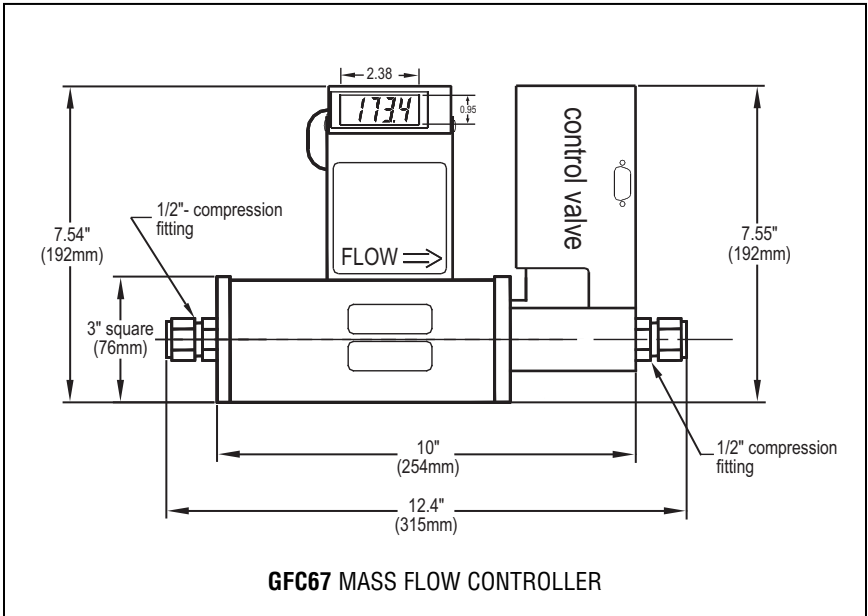
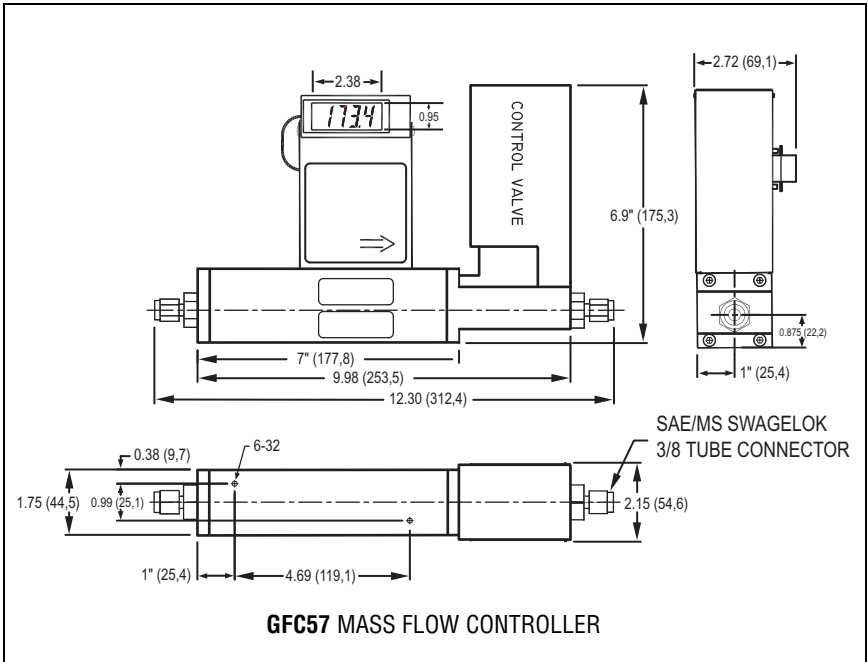

NOTE: Aalborg® reserves the right to change designs and dimensions at its sole discretion at any time without notice. For certified dimensions please contact Aalborg®.

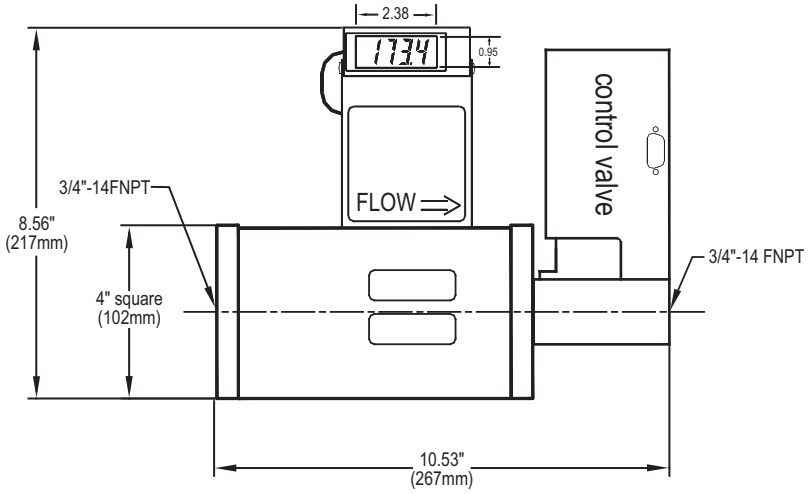

GFC77 MASS FLOW CONTROLLER

NOTE: Aalborg® reserves the right to change designs and dimensions at its sole discretion at any time without notice. For certified dimensions please contact Aalborg®.

APPENDIX 4

WARRANTY

Aalborg® Mass Flow Systems are warranted against parts and workmanship for a period of one year from the date of purchase. Calibrations are warranted for up to six months after date of purchase, provided calibration seals have not been tampered with. It is assumed that equipment selected by the customer is constructed of materials compatible with gases used. Proper selection is the responsibility of the customer. It is understood that gases under pressure present inherent hazards to the user and to equipment, and it is deemed the responsibility of the customer that only operators with basic knowledge of the equipment and its limitations are permitted to control and operate the equipment covered by this warranty. Anything to the contrary will automatically void the liability of Aalborg® and the provisions of this warranty. Defective products will be repaired or replaced solely at the discretion of Aalborg® at no charge. Shipping charges are borne by the customer. This warranty is void if the equipment is damaged by accident or misuse, or has been repaired or modified by anyone other than Aalborg® or factory authorized service facility. This warranty defines the obligation of Aalborg® and no other warranties expressed or implied are recognized.

NOTE: Follow Return Procedures In Section 1.3.

CAUTION:

This product is not intended to be used in life support applications!

The selection of materials of construction, is the responsibility of the customer. The company accepts no liability.

TRADEMARKS

Aalborg® is a registered trademark of Aalborg Instruments & Controls. *VCR®* is a registered trademark of Crawford Fitting Co.
Buna® is a registered trademark of DuPont Dow Elastometers. *Viton®* is a registered trademark of Dupont Dow Elastomers L.L.C.
Kalrez® is a registered trademark of DuPont Dow Elastomers.

NOTES: